

LabVIEW for Motor Speed Control

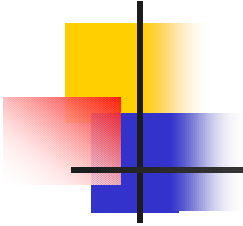

Satyaveda Bharath
Kalisha Robinson

South Carolina State University



Project Title: Remote Data Acquisition and Motor Control via Internet for Space Application

Project Goal: To control position of a robot arm remotely via Internet

Group Goal: We are responsible for the construction of the robot arm

Preparation: Become familiar with LabVIEW
Become familiar with Pulse Width Modulation

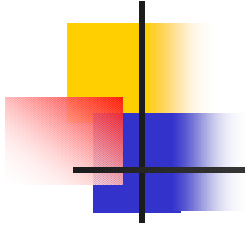

- I. INTRODUCTION
- II. PROJECT DESCRIPTION
- III. CONCLUSION



INTRODUCTION

- Open-Loop DC motor speed control system
- Pulse Width Modulation (PWM) is employed to control the speed of the motor
- A virtual instrument (vi) is developed with LabVIEW
- The vi generates a triangular wave that produces the desired PWM signal.
- PWM is an analog that switches between two predefined limits.



INTRODUCTION

- User inputs the amplitude and frequency of the triangular wave, sampling rate of the reference signal, and the desired amplitude of the PWM.
- As the reference voltage increases, the width of the PWM(duty cycle) increases which in turn increases the speed of the motor.
- The varying nature of the motor speed is demonstrated in the laboratory by changing the reference signal.
- The principle developed in this project will be utilized in future endeavor toward controlling the robot motion remotely via Internet



Project Description

The major components of the complete system include an input circuit, and output circuit, and a microcomputer with DAQ board and LabVIEW software.

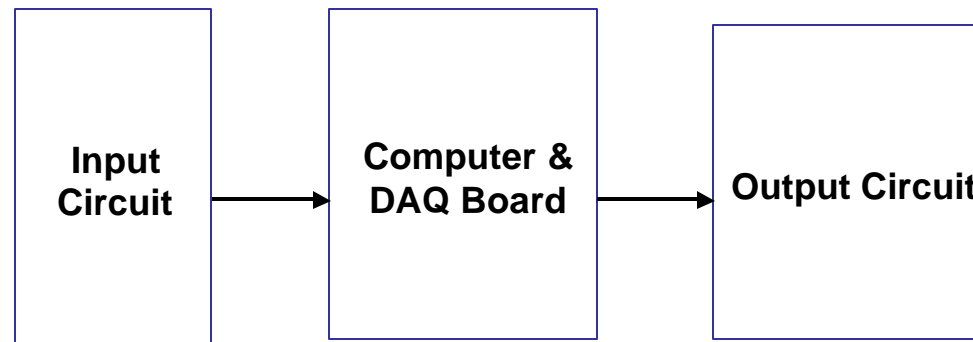

figure 1

Project Description

The input circuit shown in Fig. 2 is a simple voltage divider that employs a potentiometer and two power supplies.

It provides a variable reference signal within a range of -15V and $+15\text{V}$.

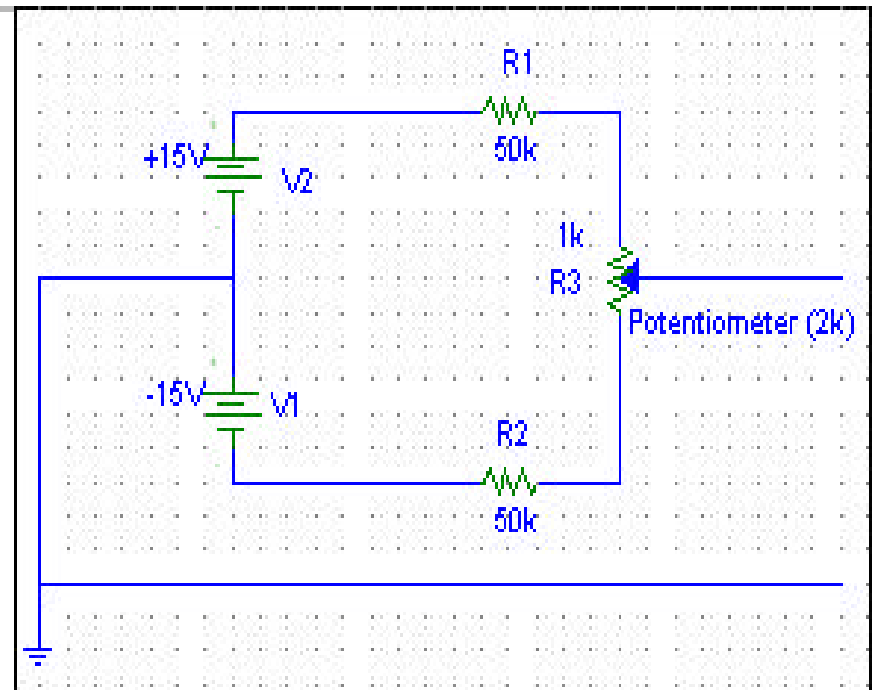

Figure 2

Project Description

- * In the output circuit , a dc motor is connected between the collector of the power transistor TIP 41 and the power supply of 40V.
- * The power transistor is used as a buffer between the output port of the DAQ unit and the motor under control.

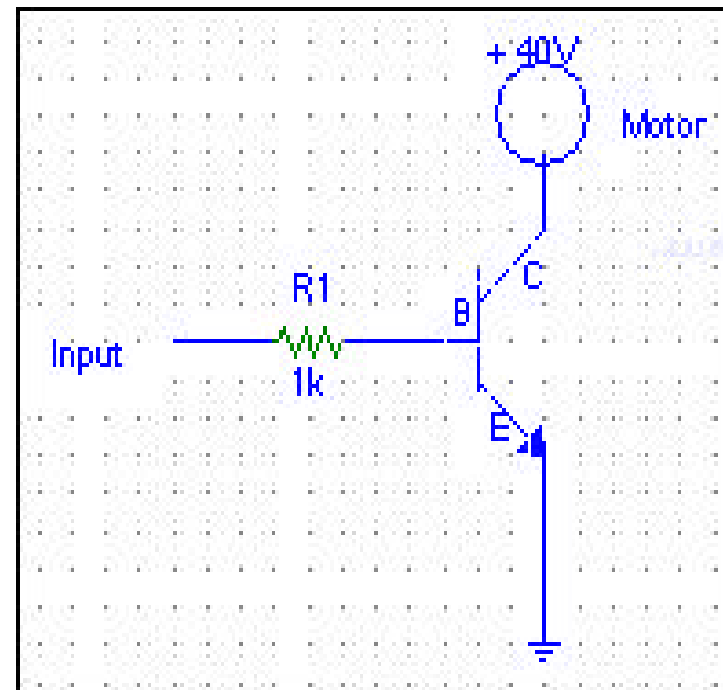

Figure 3



Project Description

- The output of the input circuit (reference signal) is connected to the input port or channel of the DAQ.
- The output circuit receives the PWM signal through the output port or channel of the DAQ

Project Description

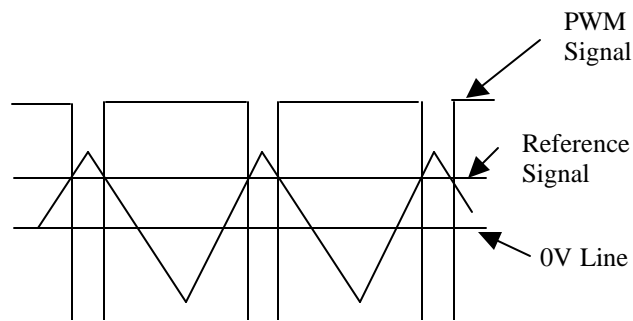
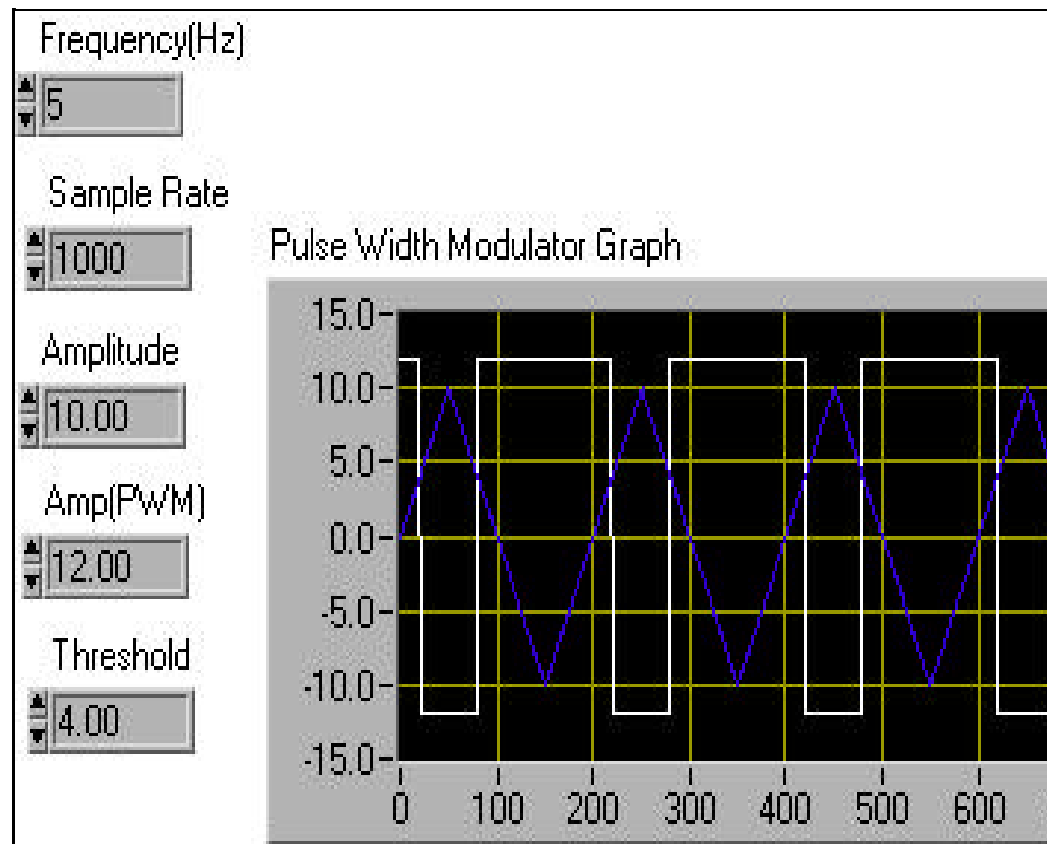

Figure 4. Pulse Width Modulation Signal

The vi developed with LabVIEW software performs the following functions such as, samples the reference continuously at the user supplied rate, generates a triangular wave, and produces a PWM signal that switches at the intersection of the reference signal and the triangular signal.

Project Description

- *The vi consists of a front panel and a block diagram
- * The front panel contains the control parameter, display, and indicators



Project Description

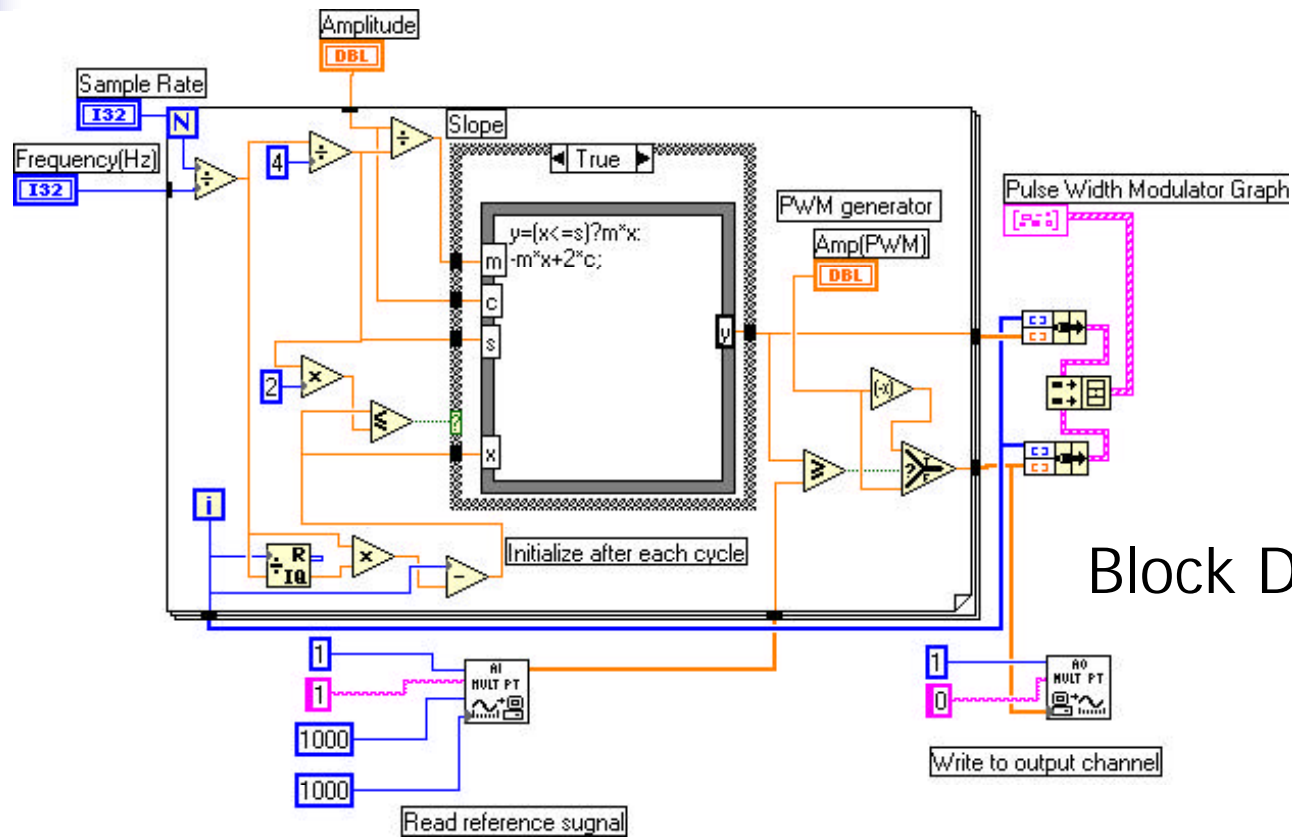

Block Diagram



Project Description

- The block diagram contains components that perform the switching of the PWM and request the DAQ board to read signal at input port and write signal to the output support as needed.



Conclusions

- A dc motor speed control system is developed by using National Instrument's LabVIEW software and data acquisition board that employs pulse width modulation.
- The functional characteristics of pulse width modulation signal can be easily adjusted with the software.
- This technique saves project development time.
- Knowledge gained and experience gathered through this project will be utilized in the remote operation of robot arm via internet.